

# TAPERED END MILLS

SPECIAL TOOLS MANUFACTURED IN MELBOURNE

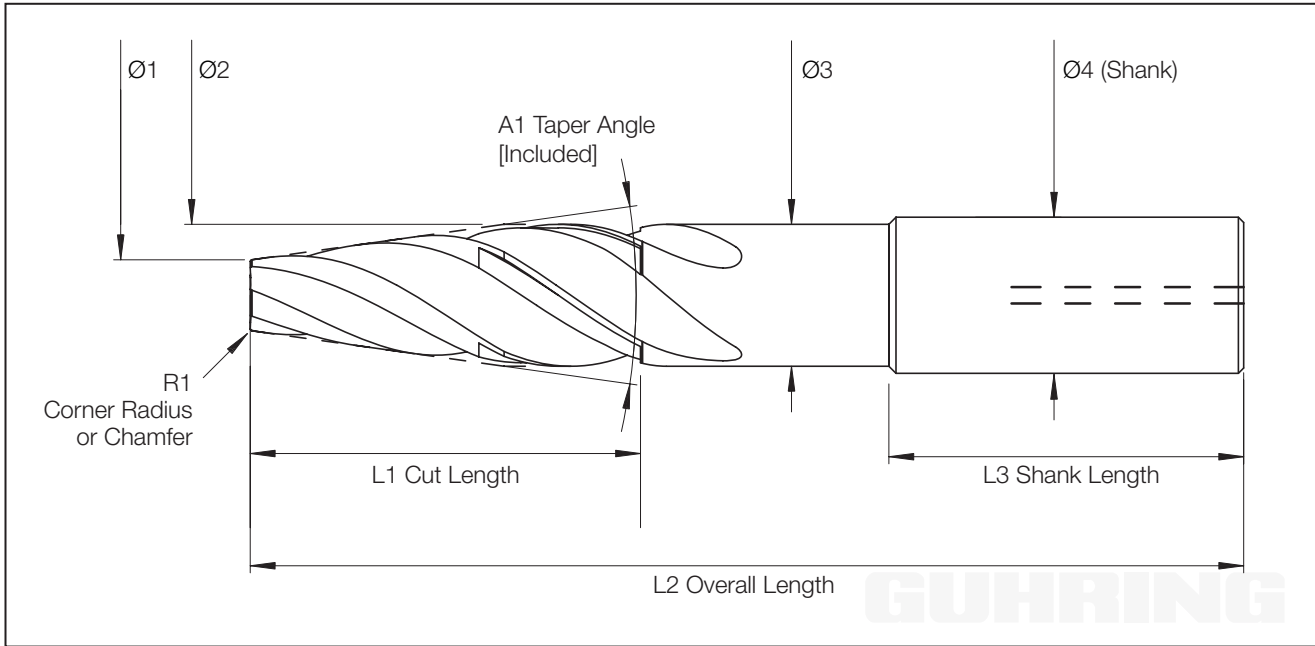

$\varnothing 1$  - Lead Diameter \_\_\_\_\_  
 $\varnothing 2$  - Nominal Diameter \_\_\_\_\_  
 $\varnothing 3$  - Neck Diameter \_\_\_\_\_  
 $\varnothing 4$  - Shank Diameter \_\_\_\_\_  
 L1 - Cut Length \_\_\_\_\_  
 L2 - Overall Length \_\_\_\_\_  
 L3 - Shank Length \_\_\_\_\_  
 A1 - Taper Angle \_\_\_\_\_  
 A3 - Helix Angle \_\_\_\_\_  
 Z - Number Of Flutes \_\_\_\_\_  
 R1 - Corner Radius \_\_\_\_\_

Internal Coolant  Yes  
 No  
 Surface  Uncoated  
 TiN  
 FIRE  
 ICE  
 ZENIT  
 End Cutting  YES  
 NO

(or) Corner Chamfer: \_\_\_\_\_ Degrees x \_\_\_\_\_ mm

Quantities for quotation:  
 Quantity 1. \_\_\_\_\_ pieces  
 Quantity 2. \_\_\_\_\_ pieces  
 Quantity 3. \_\_\_\_\_ pieces

COMPANY	NAME	DATE
ADDRESS		
PHONE	FAX	EMAIL

6 Jacks Road, Oakleigh South VIC 3167 FAX: (03) 9948 4699 E-MAIL: guhring@guhring.com.au

This drawing is the property of Guhring oHG. It is not allowed to copy it partially or completely, to publish it, or to use or communicate it for the purpose of competition without authorization.